



## Main features

### Printing type



Barcode



Logos



Alphanumeric text

### Maximum height



0-15 mm



16-100 mm



Above 100 mm

### Printing surfaces



Primary packaging



Secondary packaging



Raw material

- Special printer with an exclusive software for printing management with a moving printhead (traversing system) in longitudinal direction in relation to products feed.
- Up to 12 prints adjustable per translation, with translation speed up to 1 mt/sec (3,3 ft/sec).
- Up to 5 lines with height range from 0.8 to 14 mm with Micro Print Nozzle for high quality resolution print.
- Advanced hydraulic system for quick and easy start up with automatic visible double flushing fitting production lines with long stops.
- High degree of IP65 protection for use in all arduous industrial environments

# Z5000ITS

## TECHNICAL SPECIFICATIONS

### PRINTING CHARACTERISTICS

- Up to 5 lines of print
- Characters height from 0,8 to 14 mm (0,032" - 0,56")
- Line speed capability: up to 400 mt/min (1320 ft/min)
- Print rate: up to 2136 ct/sec
- 250 messages storage
- Up to 250 characters storage per message
- Selectable lines vertical gap
- Font Matrix: 5x4, 5x5, 7x4, 7x5, 9x7, 10x8, 15x10, 16x10, 24x16 and 32x18
- Bold factor up to 8 times
- Simple Logo creation and printing
- 50 Logos storage
- Automatic calendar and expiration date print
- Incrementing/decreasing product counters up to 9 digits
- Repeat print – message function
- Printing in all moving directions
- Tower print function (Text rotation of 90°)
- DIN print for cables sector
- Negative print function
- Coding throw distance up to 90 mm (3,54")

### BAR CODES

- 2/5 Industrial, UPC-A, CODE 39, EAN 13 CODE 128, EAN 128 (A,B,C), ITF (A,B,C) 2D - Data Matrix

### TRAVERSING FEATURES

- Fully integrated management directly from system panel - External power supply NOT needed
- Print during forward and backward translation
- Printing position management directly from the keyboard
- Translation speed: up to 1 mt/sec (3,3 ft/sec)
- Up to 12 prints adjustable per translation
- Sensor for the synchronization with the conveyor
- Adjustable fixing supports
- Stepper or brushless motors with integrated Encoder
- Automatic reverse printing
- Single (X) or double (x-y) axes traversing system

### CONTROL UNIT CHARACTERISTICS

- Membrane keyboard solvent resistant
- Blue WYSIWYG Display with high contrast 240x128 pixels
- Stainless Steel structure AISI 304
- Protection IP65
- Conduit length: 4 mt (13,1 ft)

### GENERAL FEATURES

- Single Start/Stop button
- Vapour recovery system for low make up consumption
- Advanced hydraulic system for quick and easy start up with automatic cleaning
- Print parameters storage in the messages
- Keypad access with password
- User-friendly and intuitive operator interface
- Several foreign languages
- Report function for executed printing counter
- Message storage with alphanumeric text

### PRINTHEAD

- Stainless steel and aluminium structure hermetically sealed
- Micro Print Nozzle for high quality resolution print
- Auto-phasing of ink stream for consistent print quality
- Microjet nozzle cleaning function
- Wide range of standard, pigmented, food and MEK-free inks
- Dimensions: 227 mm x 42 mm x 49 mm (9,0" x 1,7" x 1,9")
- Conduit inlet at 90° (optional)
- Internal Supply Positive Air Function

### ENVIRONMENT/ELECTRICAL REQUIREMENTS

- Temperature: from 5° to 45°C (40°-113°F)
- Humidity: 10 - 90% (non-condensing)
- Single Phase, 85-240 Vac, 50-60 Hz, 200 VA

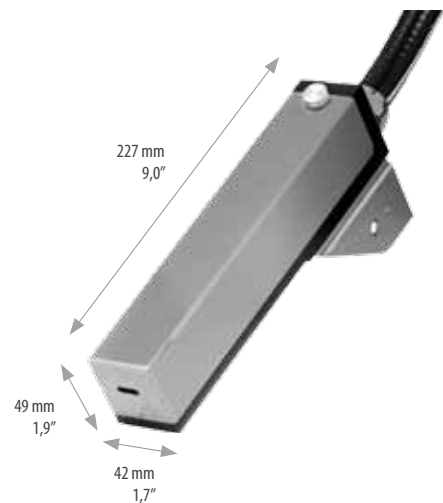

Use a QR code reader to see the product page

Zanasi S.r.l.  
Via Marche, 10  
41049 Sassuolo (MO) Italy  
Tel. +39 0536 999711  
Fax +39 0536 999765  
www.zanasi.it - info@zanasi.it

Zanasi USA  
www.zanasiusa.com

Zanasi China  
www.zanasichina.com

 **ZANASI**<sup>®</sup>  
make your mark  
www.zanasi.it